

# CGSHTFT Datasheet Hydrogen Gas Detector



**24VDC Power Input**



**Detector Should Be Used With An CGS Controller**



**Traffic Light Indicator Display Changes Color Dependent On Gas Levels**



**BMS/BAS Communications**



**Modern & Compact Design**



**Alarm Relay Dry Contact**



**Plug & Play Installation**



**In-Built Audible Alarm**

## Product Overview

The TFT range of CGS detectors work in combination with the CGS Merlin range of Gas Detection panels and Utility Controllers. The CGSHTFT features a semiconductor sensor for industrial and commercial indoor applications. Compact, modern, digital design makes the units aesthetically pleasing and easy to install.

## Popular Applications

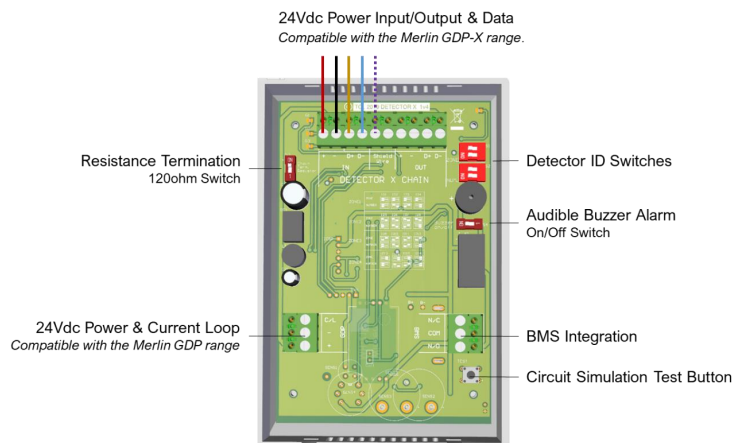

# Technical Specification

General							
Model:	Merlin Gas Detector TFT						
Target Gases:	H						
Size: (H x W x D)	5.51 x 3.74 x 1.18" (140 x 95 x 30mm)						
Housing Material:	ABS Poly lac - PA765						
Mounting:	Safe Zone - Indoor use - Wall Mounted						
Weight:	Max. 1.77oz (0.05kg)						
User Interface							
Display:	1.8" TFT						
Screen Brightness:	Non-Adjustable						
Visual Indicators:	TFT visual. Green: Normal; Yellow: Pre-Alarm; Red: Alarm						
Audible Alarm:	>70dB @ 3.28ft (1m). Quiet conditions.						
Buttons:	None						
Language:	English						
Power Supply							
Power Consumption:	90mA Max @ 24vdc						
DC Power:	12-32 VDC - Nominal 24 VDC						
Internal Fuse:	None						
Equipment							
Overvoltage Category:	III						
Pollution Degree:	3						
I/O							
Relay:	Volt Free (Normally Closed / Common / Normally Open) 1x 30vdc 2A (Non-Latching)						
Environmental							
Ingress Protection:	Not Formally Evaluated						
Operating:	-10 ~ 50°C / 14 ~ 122°F 30 ~ 80% RH (non-condensing)						
Storage:	-25 ~ 50°C / -13~122F° up to 95% RH (non-condensing)						
Altitude Rating:	2000m						
Wiring							
Typical	#15AWG Power Pair; #18AWG Data Pair-Tinned copper.						
Approvals							
Electromagnetic Compatibility and Electrical Safety	BS/IEC/EN 61010-1 EMC EN 50270						
Other							
Communication	RS485 MODBUS RTU						
Gas Sensor	Indicating Range	Steps	Response (t90)	Recovery (t10)	Alarm: 1 (Pre alarm warning)	Alarm: 2	*EOL (Years)
Hydrogen (H)	0-20% LEL	0.1	<30s	<30s	▼8% LEL	▼10% LEL	10

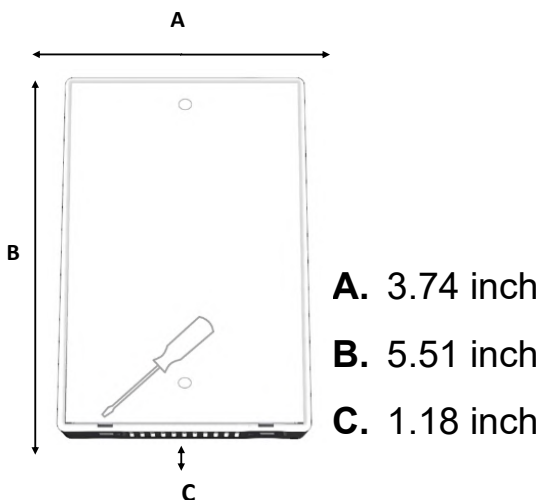

## Area of coverage

Consider the coverage required and function of the area. Emphasis should be placed on airflow patterns and correct placement, not perceived detecting ranges. The target gas will only be identified when contact is made with the sensing element itself.

The CGSHTFT monitor should be installed approximately 1ft from ceiling.

Find out more  
**Canadian Gas Safety Inc**  
[www.canadiangassafety.com](http://www.canadiangassafety.com)

Head office: 150 King Street West Suite 200,  
 Toronto, ON M5H 1J9  
 Tel: (647) 577-1500  
 Email: [info@canadiangassafety.com](mailto:info@canadiangassafety.com)

