

# CGSENCSS

## Datasheet

### Stainless Steel Solenoid Valve Enclosures



### Product Overview

Designed for general purpose indoor commercial use to enclose mechanical valves such as solenoid valves & ball valves. The hinged cover with latch provides easy access during installation and maintenance.

### Standards



### Construction

- ✓ Continuous seam welded 16 gauge steel or stainless steel construction
- ✓ Hinged cover clamps to the base with keyed quarter turn latch for a watertight seal
- ✓ External mounting brackets allow box to be mounted on a wall or panel without having to remove the cover and exposing internal components to the environment
- ✓ Bonding studs for grounding are provided on base and door
- ✓ Internal panel and hardware included
- ✓ Easily machined and modified to your particular requirements
- ✓ Rigid door design
- ✓ Continues gasket
- ✓ Bar folded flange to enhance seal performance
- ✓ Additional rubber washer inside mounting brackets to enhance water resistant seal
- ✓ Added locks in larger size enclosures

### Finish

- ✓ Smooth gray powder coat, Internal Panel - Clear Zinc plate

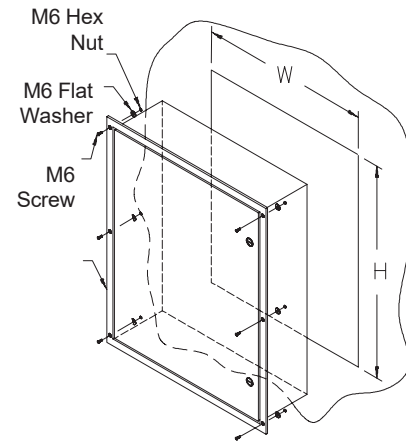

Part Code	Height ± .25	Width ± .25	Depth ± .25
CGSENC12126SS	12inch	12inch	6inch
CGSENC16126SS	16inch	12inch	6inch
CGSENC20168SS	20inch	16inch	8inch
CGSENC24208SS	24inch	20inch	8inch
CGSENC242410SS	24inch	24inch	10inch

Find out more  
**Canadian Gas Safety Inc**  
[www.canadiangassafety.com](http://www.canadiangassafety.com)

Head office: 150 King Street West Suite 200,  
 Toronto, ON M5H 1J9  
 Tel: (647) 577-1500  
 Email: [info@canadiangassafety.com](mailto:info@canadiangassafety.com)

