



Water Leak Detection

Design Guideline



Canadian Gas Safety Inc
www.canadiangassafety.com

Revision 7

Contents

WLM Puck Attachments	3
WLM 2-Core Rope Attachments.....	4-5
WLM 4-Core Rope Attachments.....	6-8
WLM Water Valves.....	9
WLM Controller Capabilities.....	10
WLM Wiring Appendix.....	11

WLM Puck Attachments

Water Leak Pucks

A water leak detection puck is a compact and highly sensitive device designed to identify water leaks or flooding in precise locations. The puck uses a set of metal probes located on the underside to detect the presence of water. When the probes come in contact with water, they complete an electrical circuit, which triggers an alarm on the WLM.

It is important to note this device cannot detect distilled water, as it does not conduct electricity.

Water leak pucks DO NOT include fault detection.

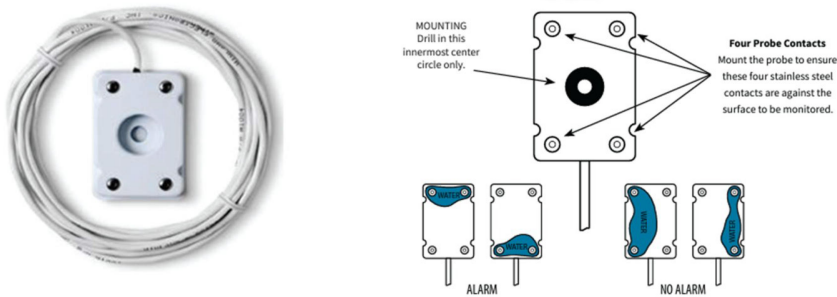

Puck Set Ups From Controller

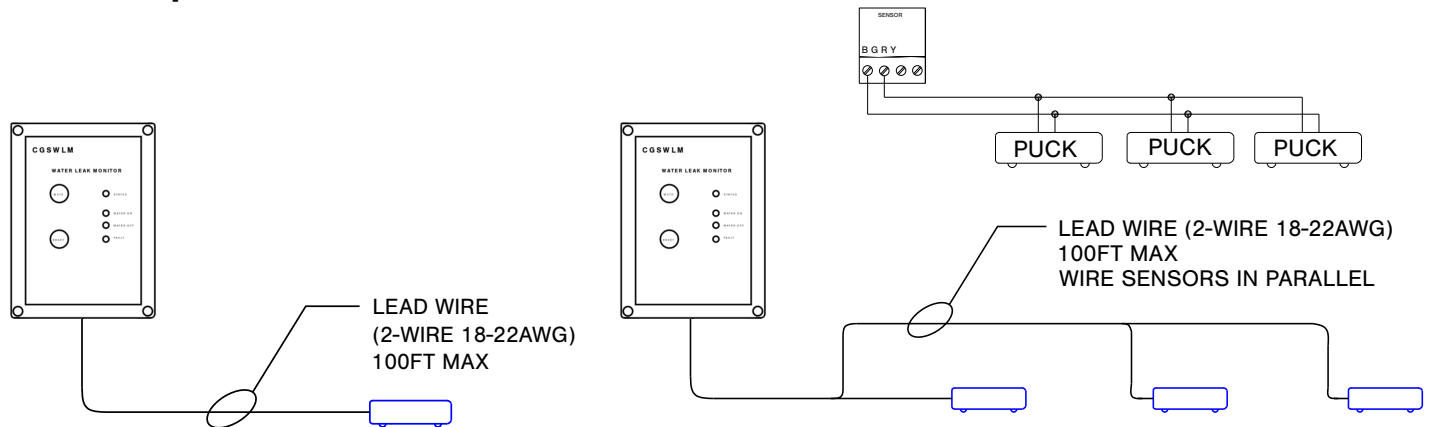

Lead Wire

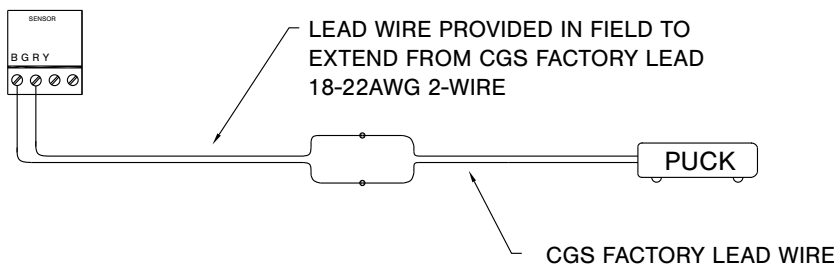

Part Codes

Attachment Description	Part Code	Length (FT)	Fault Detection (Y/N)
Detection Ropes - Pre Defined Lengths 2-Core			
2-Core Point Of Leak Sensing Puck w/ 15ft Lead Wire	CGSP		

WLM 2-Core Rope Attachments

Leak Detection Cable Overview

Water leak detection cables are designed to identify leaks in large spaces. They are commonly used along water piping or in buildings, data centers, and industrial facilities. When water contacts any part of the cable, it establishes a conductive path, causing a change in electrical resistance or capacitance. The WLM detects this change and enters alarm.

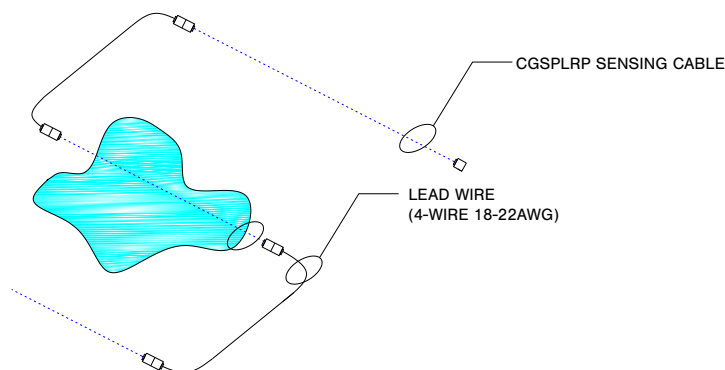

4-Core



2-Core

Pre-Defined Length 2-Core Leak Cable

2-Core leak detection ropes include a 5m lead wire, however this wire may be extended using 18-22 AWG. The total length of lead wire and sensing cable may not exceed 500FT.

If more than 500FT is required, use multiple WLM controllers.

Pre-Defined 2-Core DO NOT include fault detection.

The 2-Core sensing cable is a much more affordable option if only a single desired length is required for the project.

Available Lengths: 6FT, 12FT, 24FT, 48FT, and 100FT.

Methods to Secure the Rope

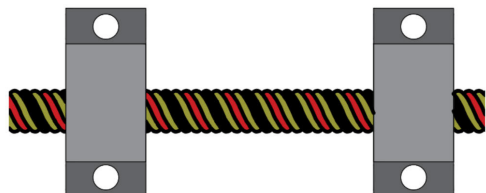

Hold Down Clips

Come with adhesive backing or may be screwed down



Zip Ties

Secure along piping

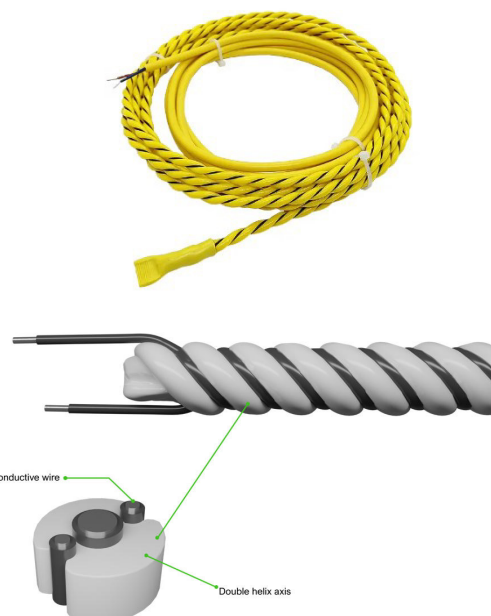

WLM 2-Core Rope Attachments

2-Core Example Set Ups

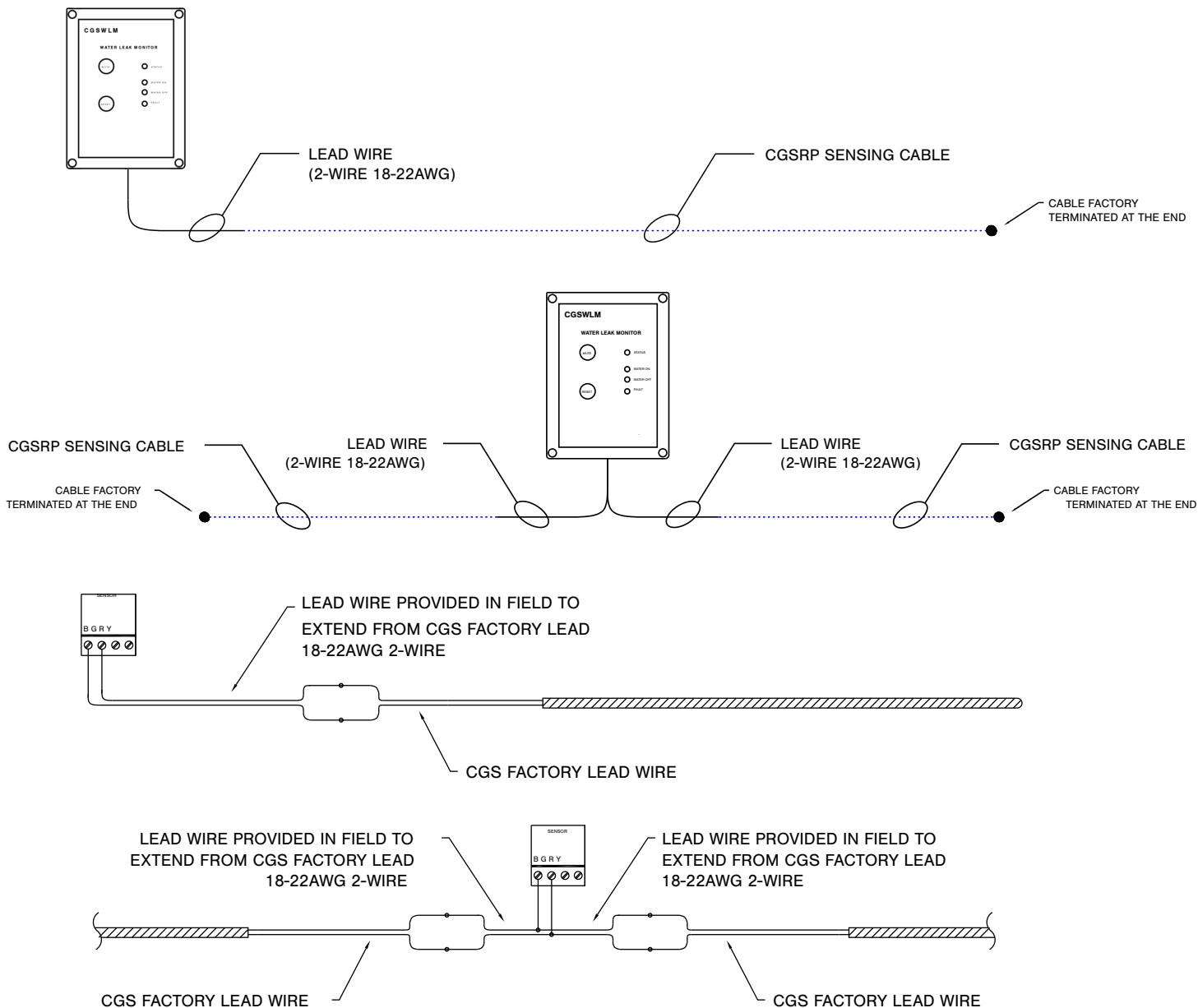

Part Codes - 2-Core

Attachment Description	Part Code	Length (FT)	Fault Detection (Y/N)
Detection Ropes - Pre Defined Lengths 2-Core			
6FT Sensing Cable w/ 5FT Lead Cable	CGSRP6	6	N
12FT Sensing Cable w/ 5FT Lead Cable	CGSRP12	12	N
24FT Sensing Cable w/ 5FT Lead Cable	CGSRP24	24	N
48FT Sensing Cable w/ 5FT Lead Cable	CGSRP48	48	N
100FT Sensing Cable w/ 5FT Lead Cable	CGSRP100	100	N
Custom Pre-Defined Length Call CGS For Pricing	CGSRPxx	xx	N

WLM 4-Core Rope Attachments

Pluggable 4-Core Leak Cable

4-Core ropes DO include fault detection.

They come at a slightly premium cost, but with many adaptable set ups to fit custom applications.

4-Core ropes are terminated with plugs that allow you to link multiple sensing cables together. This can be used for branching the rope into tees or adding lead wire in between sensing cables.

The pluggable ropes come with less options for length due to the ability to link multiple smaller cables together to create a larger rope.

4-Core leak detection ropes include a 5m lead wire, however this wire may be extended using 18-22 AWG. The total length of lead wire and sensing cable may not exceed 500FT.

In example set up 3, two (2) additional lead wires will have to be purchased and wired together to create the branch in between the two sensing cables.

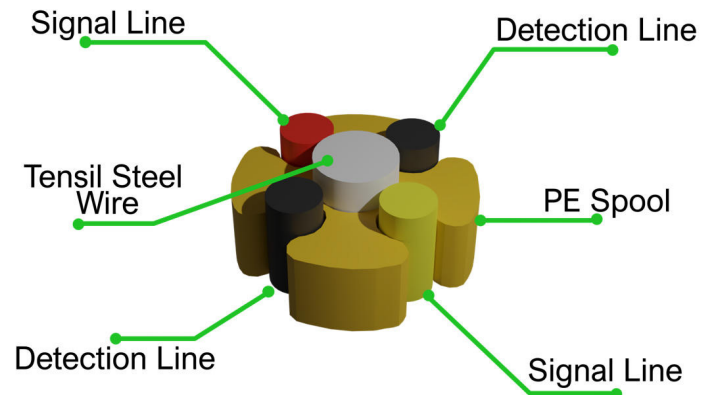
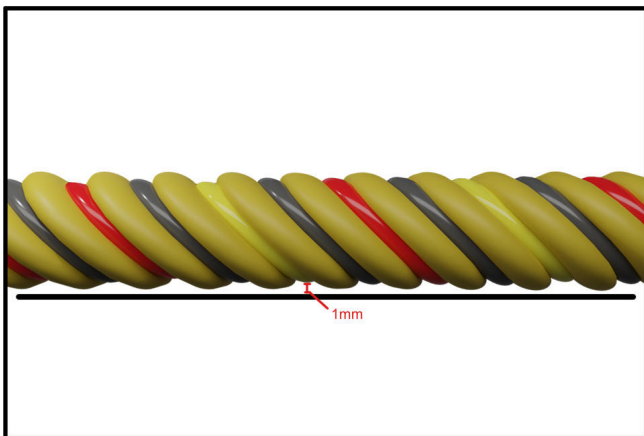
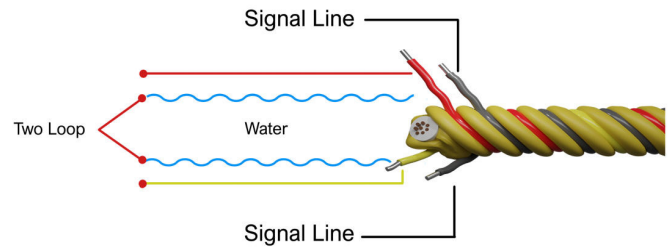

WLM 4-Core Rope Attachments

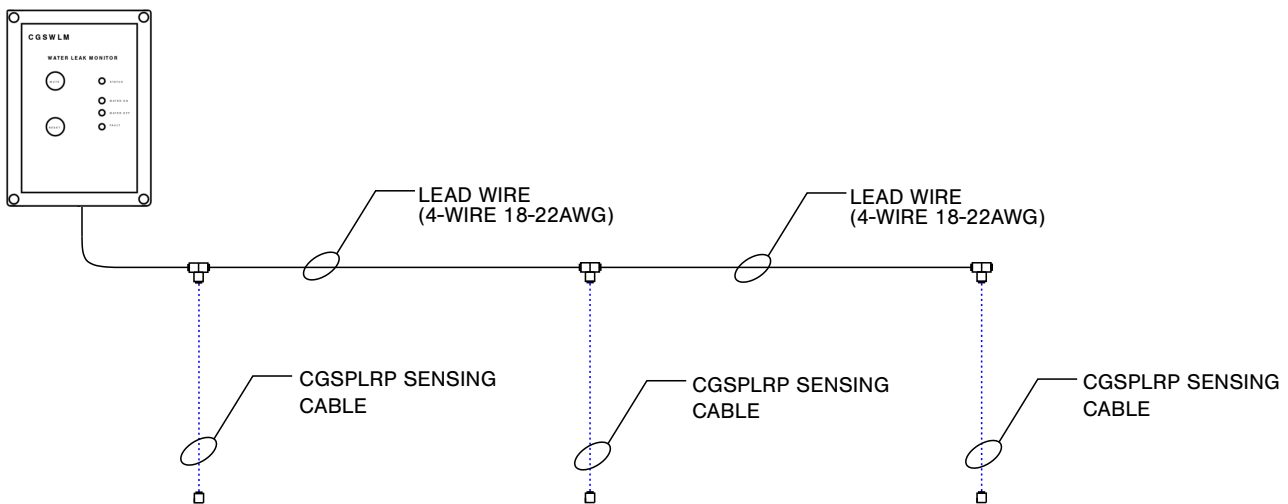
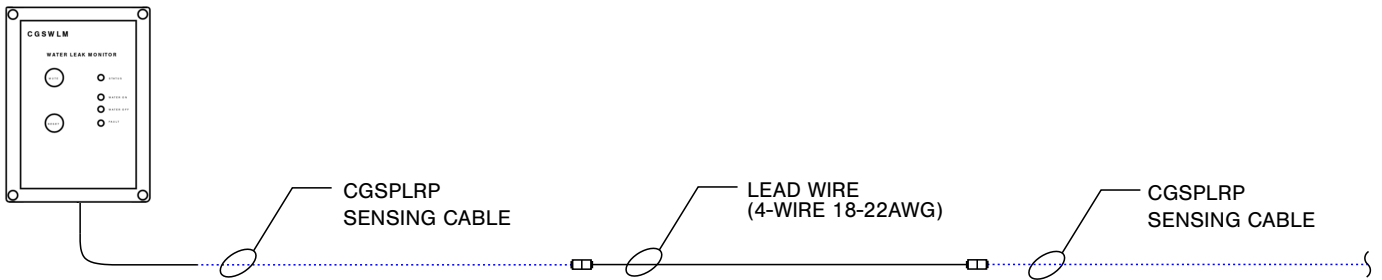
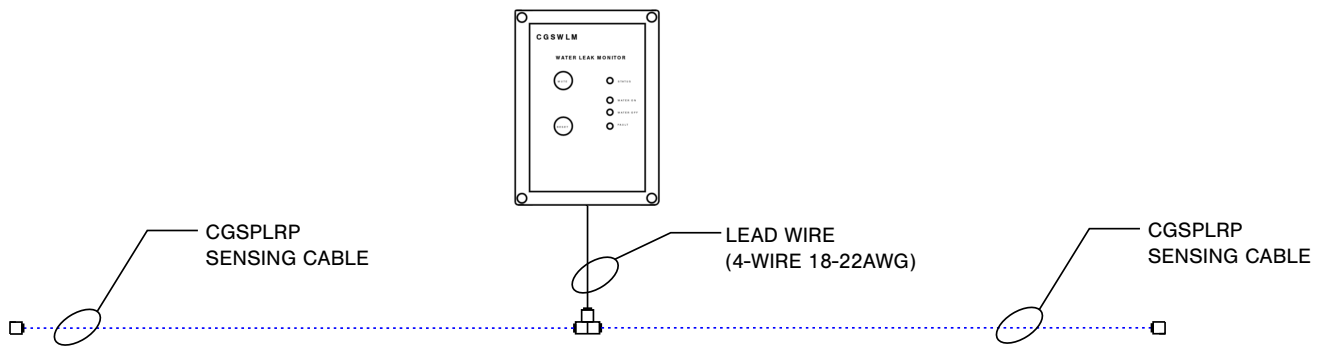
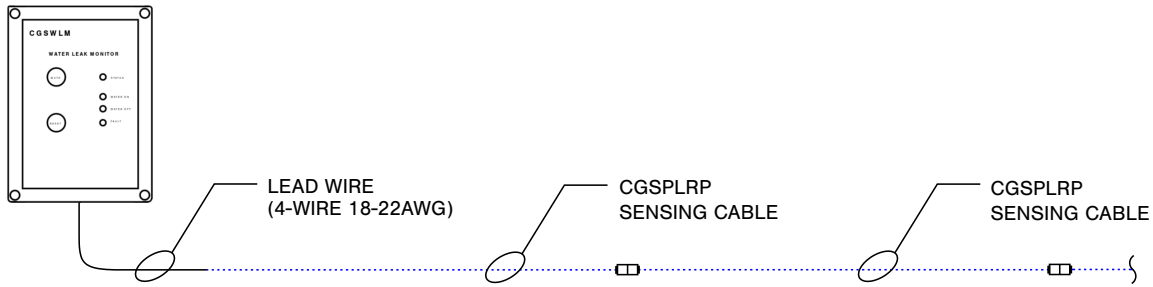

WLM 4-Core Rope Attachments

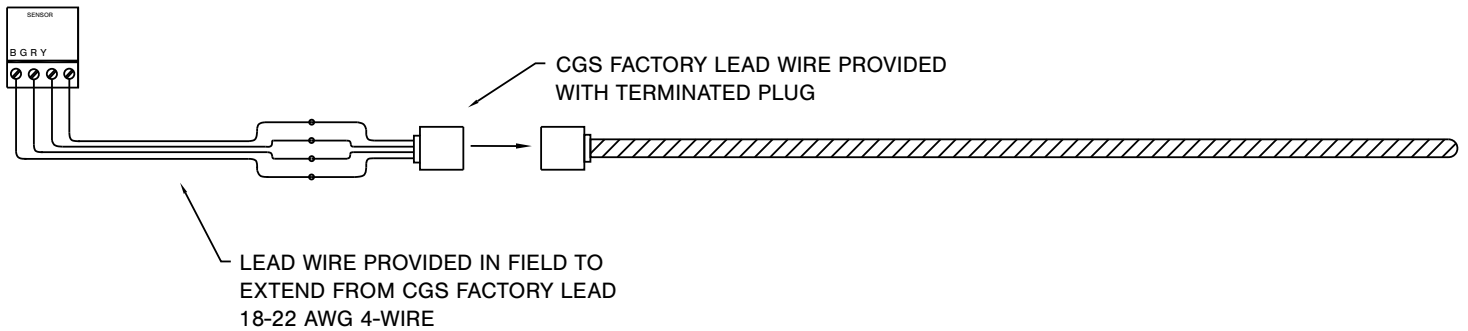
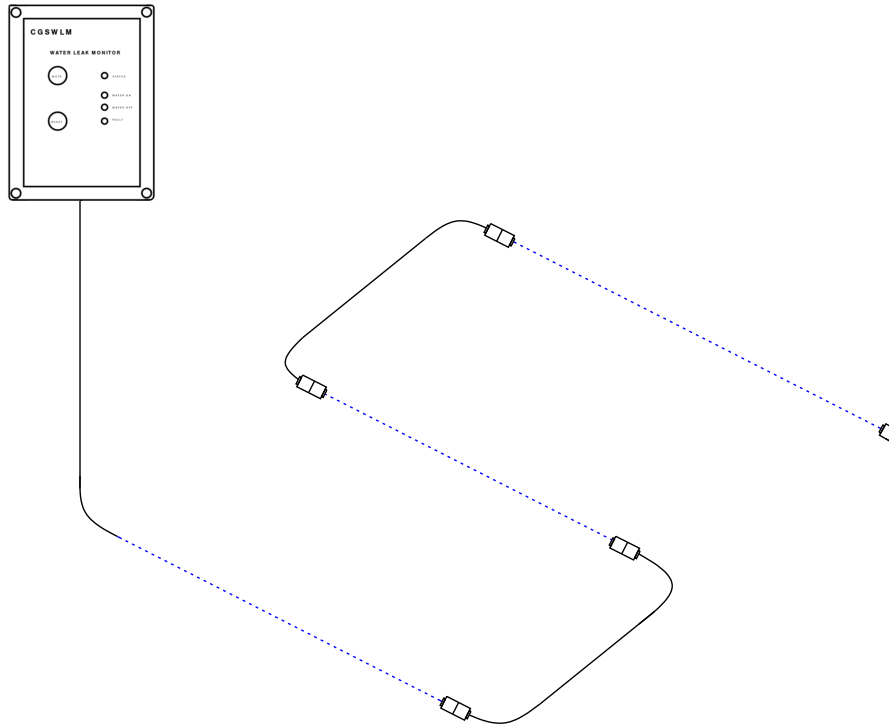

Part Codes 4-Core

Attachment Description	Part Code	Length (FT)	Fault Detection (Y/N)
Detection Ropes - Pre Defined Lengths 2-Core			
16FT Sensing Cable w/ 5FT Lead Cable (5M)	CGSPLRP16	16	Y
32FT Sensing Cable w/ 5FT Lead Cable (10M)	CGSPLRP32	32	Y
65FT Sensing Cable w/ 5FT Lead Cable (20M)	CGSPLRP65	65	Y
Rope Tee Attachment	CGSPLRPTEE		
Plug End Lead Wire	CGSPLRPLEAD		

WLM Water Valves

Valve Options

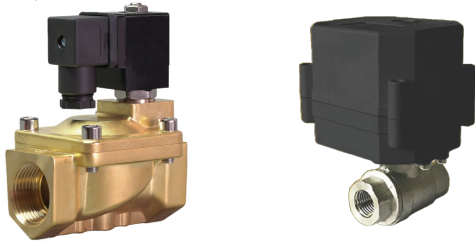

Two CGS valve types are available. The CGSOLVLV series is a direct acting solenoid valve for reliable long-term operation, and faster closing.

The CGSEBV series are electronic motorized ball valves. They consume less power and allow for more valves to be connected to one unit if maxed out on solenoids. They are slow closing, removing need of a water hammer arrestor, however a leak will isolate much slower.

True normally closed valves (mechanically closing after power loss) are only available with direct acting solenoids. EBVs require power to open, and power to close. Normally Closed EBVs use an internal capacitor to store energy, and power the valve closed. If this capacitor fails, the valve will not close.

For critical applications, solenoid valves are recommended, however for less critical applications, an EBV may be a suitable option.

Normally Open vs. Normally Closed

Normally Open and Normally Closed valve options are available.

If there is any power outage, or system failure, a normally closed valve will shut and isolate the water supply whether it is warranted or not. This must be considered when selecting orientation.

Opting for a normally open valve enables independent water supply, eliminating dependence on the WLM and it's operational status.

It is unlikely that a WLM would inadvertently de-energize a normally closed solenoid valve. Interruption of the controller power supply, or physical damage to the unit are the only two factors that would cause inadvertent closing of the valve.

A normally open solenoid allows for a faulty system to potentially go un-serviced.

If there is a subsequent power cut and water leakage, the WLM will not be able to close a normally open solenoid.

For critical applications, a normally closed valve is recommended.

24V or 120V Solenoid Valves

24V and 120V solenoid valves are available. The WLM must be powered with the same voltage as the valve selected.

WLM Controller Capabilities

Controller Capabilities

The CGS WLM Water Leak Monitor is designed to be a stand-alone controller or may be used with our range of CGSWLMZ controllers.

The CGS WLM is designed to receive inputs from a variety of leak sensing attachments including pucks and sensing ropes.

The relays on the WLM can be adapted for unique applications, but serve standard functions as follows:

- Audible and Visual Strobe Output
 - For an additional alarm. The WLM has a built in audible alarm.
- BMS Connectivity
 - Fault detection and alarm signal.
 - Fault detection only works with 4-Core ropes.
- Valve Isolation
 - 24V or 120VAC Water Valves
 - Power the controller with the same voltage as specified solenoid for easy wiring.

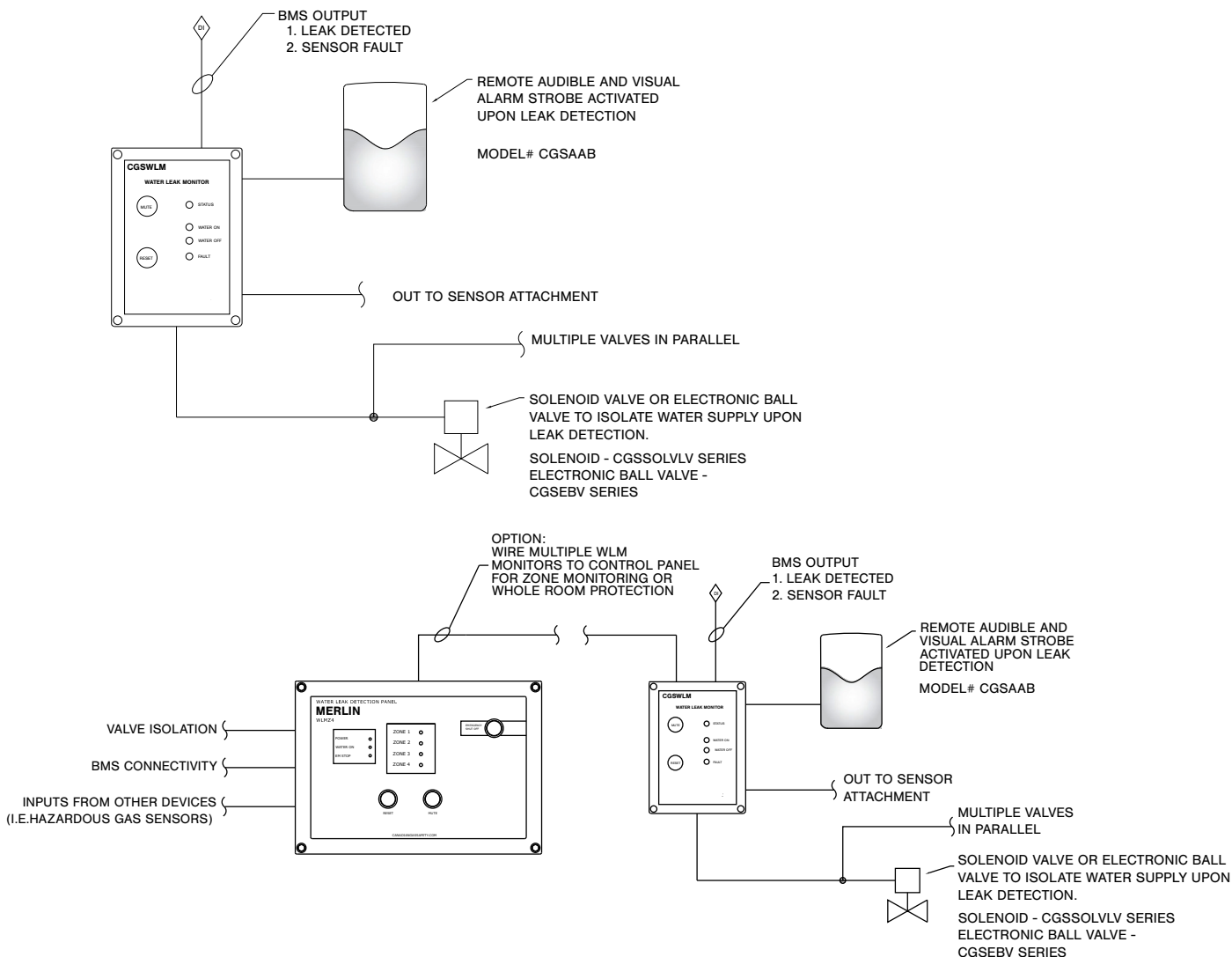

WLM Wiring Apendix

24VAC SOLENOID VALVE
NORMALLY OPEN

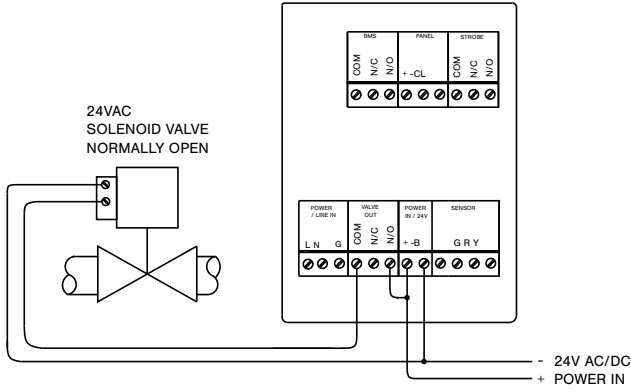

24VAC SOLENOID VALVE
NORMALLY CLOSED

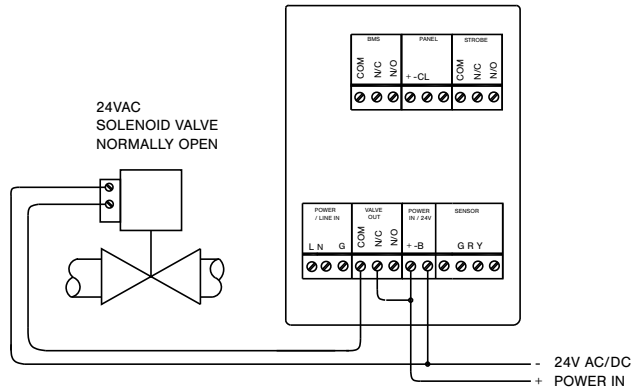

120VAC SOLENOID VALVE
NORMALLY CLOSED

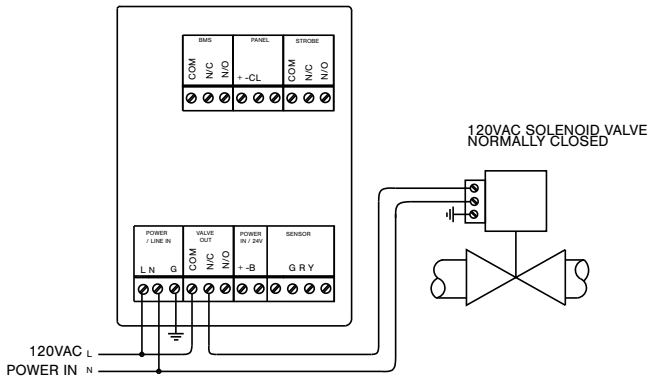

120VAC SOLENOID VALVE
NORMALLY OPEN

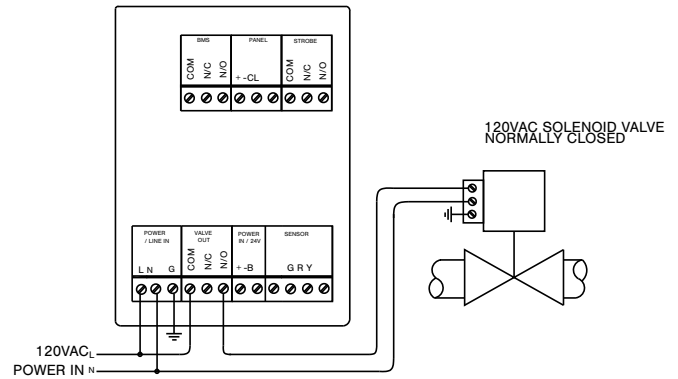

STROBE WIRING

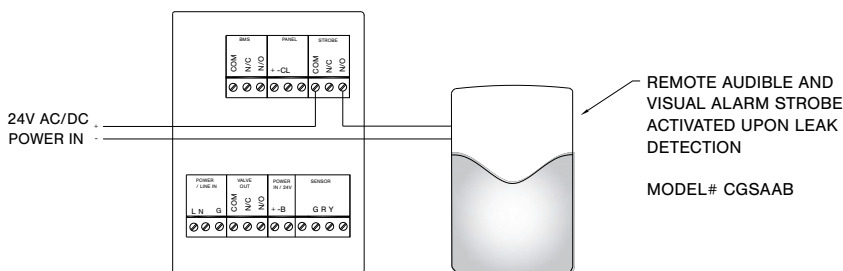

BMS WIRING

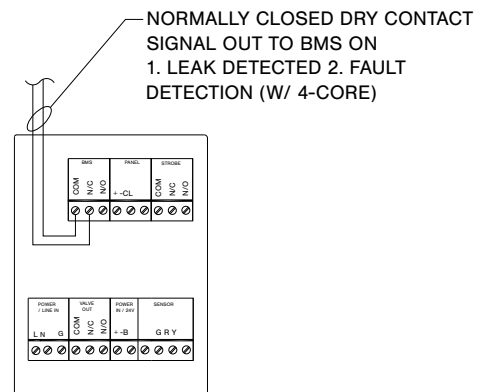

Canadian Gas Safety Inc

www.canadiangassafety.com

Head office:

150 King Street West, Suite 200, Toronto, ON M5H 1J9

Tel: (647)-577-1500

Email: info@canadiangassafety.com

